

Soft Served Karma Soft Ice Cream Dispenser, 130cones/h (70gr) or 9kg, pump

ITEM # _____

MODEL # _____

NAME # _____

SIS # _____

AIA # _____



560028 (KARMAP)

Soft ice cream dispenser with 4,5 l tank capacity and 2,3 l cylinder volume, hourly production: up to 130 cones (75 gr) or 9 kg, pump version, R452A

Short Form Specification

Item No. _____

Ideal for the preparation of soft serve ice cream and frozen yogurt. Hourly capacity: up to 130 cones (9 kg/h). Defrost/night mode: temperature will settle at 0/+2°C and the product will remain fresh without getting stressed; turning on again the freezing system the product will be ready in a few minutes. Stainless Steel panels. Minimum level warning light. Pump feeding system.

Main Features

- Ideal for serving of soft serve ice cream and frozen yogurt.
- Defrost/night mode: to activate push on the key with the - symbol until all led lights are off. By this way temperature will settle at 0/+2°C and the product will remain fresh without getting stressed; turning on again the freezing system the product will be ready in a few minutes.
- Minimum level warning light.
- Customizable dispensing lever.
- Small and silent machine.
- Pump feeding system.
- Hourly capacity (up to): 130 cones (5 kg/h).

Construction

- Stainless Steel panels.

APPROVAL: _____

Front

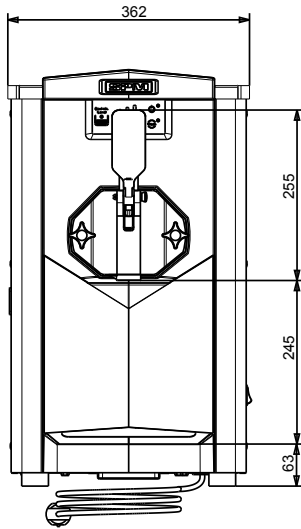

Side

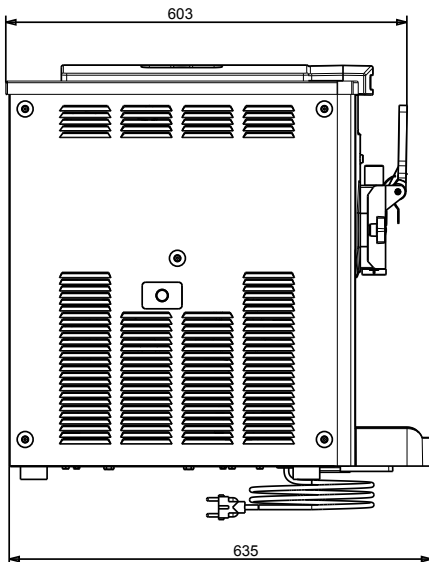

Top

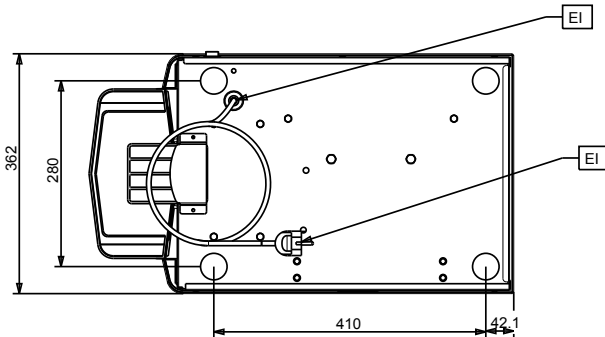

Electric

Supply voltage:

560028 (KARMAP) 220-240 V/1 ph/50 Hz

Electrical power max.:

1.15 kW

Key Information:

External dimensions, Width:	357 mm
External dimensions, Depth:	521 mm
External dimensions, Height:	657 mm
Net weight:	75 kg
Freezing cylinder capacity:	2.3 l
Preparation system:	pump
Plug type:	CE-SCHUKO

Sustainability

Refrigerant type:	R452A
Refrigerant weight:	296 g

Soft Served
Karma Soft Ice Cream Dispenser, 130cones/h (70gr) or 9kg, pump

The company reserves the right to make modifications to the products without prior notice. All information correct at time of printing.